

# Half-year Financial Report 2016

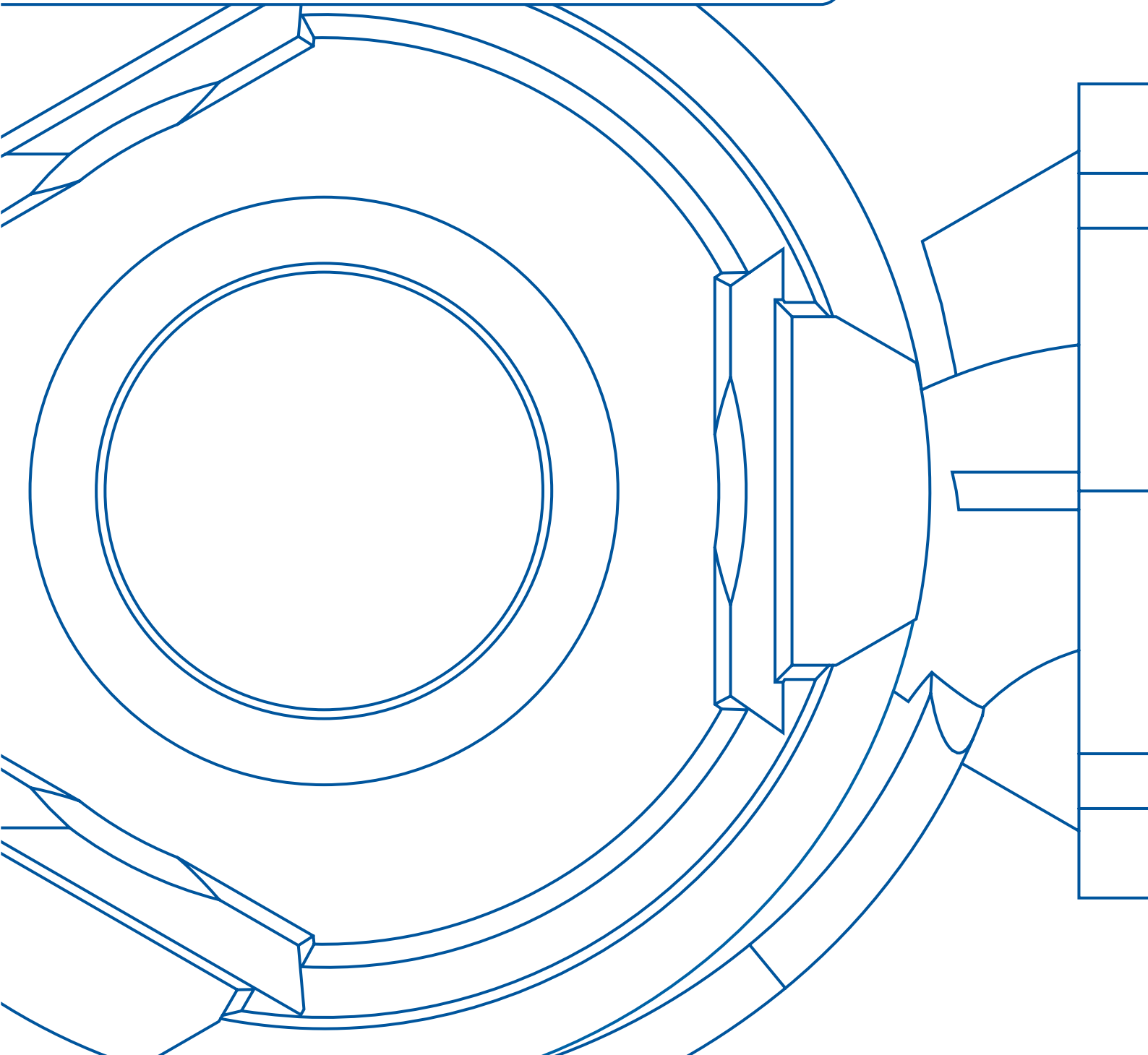

# CONTENTS

4	Interim Management Report
10	Interim Consolidated Financial Statements
10	Balance Sheet
11	Statement of Comprehensive Income
12	Statement of Changes in Equity
14	Statement of Cash Flows
15	Notes
27	Responsibility Statement
28	Contacts
29	Financial Calendar

# INTERIM MANAGEMENT REPORT FOR THE SIX MONTHS ENDED 30 JUNE 2016

## MACROECONOMIC ENVIRONMENT AND SECTOR VIEW

The International Monetary Fund (IMF) revised its 2016 forecast for world growth downwards during the first half of the year. The UN organisation now expects growth of just 3.1 %, in contrast to its previous forecast of 3.4 % as quoted in our 2015 Annual Report.

In addition to new risk factors such as Brexit, the main reasons for this are the only moderate upward trends in those countries with struggling economies and the slow pace of economic growth in the USA during the first quarter of 2016.

In Europe, which remains KSB's major sales market, there have, however, been emerging signs of moderate growth during the reporting period, driven by strong levels of domestic demand and rising investment. In the manufacturing sector, a positive development was recorded in several countries of Central and Southern Europe. In France, however, companies operating in this sector have faced an ongoing decline in orders ever since March.

In India, where KSB has a strong market position, the economy recovered. However, this improvement was based primarily on demand for consumer goods. Orders placed by Indian customers for industrial goods, including pumps and valves, remained subdued. In China, the Asian market that offers the greatest prospects for KSB, economic growth was stimulated by an expansionist fiscal policy and infrastructure spending, although industrial production continued to fall. Brazil and Russia remained in recession, despite rising commodity prices.

### CURBED DEMAND

KSB operations are mainly geared towards industry, the water and waste water sector, and energy supply companies, as well as – with regional focuses – on the construction/building services and mining sectors. Of these five markets, it was primarily the water and waste water sector, as well as construction/building services that performed positively during the first six months. China, India and the USA, as well as the Region

Middle East/Africa, generated impetus for growth as they invested in the expansion of their water supply and waste water treatment infrastructure. The construction/building services sector also performed well in several countries, buoyed by current low interest rate levels.

In industry, the most important sector for KSB in terms of sales revenue, the manufacturing segment grew slightly in some European markets and in smaller Asian markets. The chemical industry also stepped up its investment levels. In the petrochemical industry in particular, however, the low oil price contributed to many companies' marked reluctance to expand or modernise their processing plants. Orders placed with pump and valve manufacturers were correspondingly down.

Demand from energy supply companies and the mining sector continued to be weak. Reasons were the slowdown in electricity consumption and an only moderate recovery in commodity prices. Mine operators continued to cut back on investment and maintenance expenses.

### STAGNATING GROWTH IN MECHANICAL ENGINEERING

According to provisional figures, sales revenue in the mechanical engineering sector for the first half of the year was similar to the previous year's level worldwide. This is in line with the forecast of the German Engineering Federation (VDMA) for the full year, according to which companies in the euro zone can also expect zero sales growth from machinery and systems. Internationally, sector growth in some Asian and South American countries may offset the dramatic falls in struggling economies such as Brazil and Russia.

At the end of May, the VDMA revised its sales revenue forecast for liquid pumps from +1 % to –3 %. German producers recorded a decrease of 0.4 % during the first six months of 2016.

As far as industrial valves are concerned, the VDMA continues to expect sales revenue to decline by 1 %. Sales revenue recorded by the German valve industry fell 4.1 % in the reporting period.

## BUSINESS DEVELOPMENT AND RESULTS OF OPERATIONS

We have worked intensively during the first half of 2016 to bring key areas of our operations into line with the changed market conditions. In particular, we have introduced further far-reaching measures to improve our cost structure. The starting point is our Efficiency Improvement Programme, put in place to cut our material, staff and overhead costs by some € 200 million by 2018.

At the same time, we reviewed our position in the current growth markets of water/waste water and construction/building services before taking steps to make our range in these markets even more attractive. An improved product range for construction/building services applications and our strong focus on sales-oriented measures in the water/waste water sector played a key role.

At mid-year, we established our new series production facility in Ankara for our customers in building services. We will be producing circulator pumps there in future. Compared with previous production in Central and Northern Europe, this facility provides cost advantages, which will make it easier for us to offer our products at attractive prices.

We continued to establish production facilities for power plant pumps in Asia. This measure takes into account predicted investments in new power plant projects in China and India over the medium and long term. In Europe, in contrast, we have shifted the focus of our activities onto service activities for existing energy facilities.

### ORDER GROWTH LIMITED TO SERVICE ACTIVITIES

Our Group companies received orders with a total value of € 1,098.3 million during the first half of 2016. This was a reduction of € 54.5 million or 4.7 % compared with the first six months of the previous year. Negative currency effects were the main factor responsible for this decline. These primarily related to orders of the companies in China, India, South Africa and South America recorded in the respective countries' national currencies and converted by us to our Group currency, the euro.

Order levels fell across all four Regions: Europe, Middle East/ Africa, Asia and Americas/Oceania. This development was particularly marked in North America, where there were no large-scale orders for power station products, in contrast to the previous year. Orders received by KSB AG, totalling € 386.6 million for the first six months, were down 2.1 % on the comparative prior-year period.

In our largest business segment, Pumps, the order volume of € 690.8 million was € 55.0 million down on the first half of 2015. This equates to a fall of 7.4 %. The main factor responsible for this decline was the state of the new pumps business in power plant engineering, which remained difficult. There was also a tangible dip in orders from the petrochemical sector compared with 2015.

In the Valves segment, muted demand from industry, including the chemical and petrochemical sectors, was the main reason for falling order levels. Orders for special valves for use in liquefied gas tankers were also down. As in the previous year, the weak performance of the oil and gas market meant that shipping companies were reluctant to invest in new vessels. In contrast, order intake for valves for water engineering showed a clearly positive development. Overall, the Group posted valve orders worth € 180.3 million, down 9.0 % on the comparative prior-year period.

We recorded strong order growth in our Service segment, with a particular increase in the volume of service business relating to power plants. Through services and the related spare parts, we achieved a total order volume of € 227.2 million, a year-on-year increase of 8.8 %.

### EXCHANGE RATE-RELATED DECLINE IN SALES

Negative currency effects prevented a positive development in sales revenue. Consequently, sales revenue totalled € 1,064.6 million, down 3.1 % on the first six months of 2015. Sales revenue in Asia remained constant, despite currency exchange losses, while the companies in the Region Americas/Oceania experienced a considerable decline. This can be primarily attributed to fluctuating exchange rates, but also to the economic difficulties in Brazil. Sales revenue also fell in the companies in the Regions Europe and Middle East/Africa.

KSB AG, however, was a positive exception, recording sales revenue growth of € 6.6 million to € 388.6 million.

Sales revenue for Pumps was more or less stable during the first six months of 2016 compared with 2015, and amounted to € 714.2 million, a slight increase of 1.4 %. The figures posted by the companies in Europe grew more strongly than in other regions, boosted by the invoicing of large-scale pump orders placed in prior years.

Sales revenue for Valves was considerably weaker than pump sales revenue. At € 172.6 million, the former was down 6.6 % year on year. This decrease can be attributed to a large degree to shipping companies' reluctance to invest in new transport ships equipped with cryogenic technology.

Sales revenue in the Service segment dipped slightly, down 1.8 % on the first half of the previous year to € 182.0 million. In contrast, we achieved a considerable increase mainly in the companies in the Region Middle East/Africa.

#### ORDERS ON HAND

Our orders on hand amounted to a good € 1.2 billion by the middle of the year, representing a year-on-year decrease of approximately € 94 million. Orders on hand cover an unchanged production period of approximately seven months.

#### TOTAL OUTPUT OF OPERATIONS

At € 1,083.3 million, the total output of operations was 5.3 % down on the prior-year figure of € 1,144.5 million. This was influenced by the above-mentioned changes to sales revenue and a decrease of € 27.4 million in inventories.

#### INCOME AND EXPENSES

The cost of materials fell by € 41.9 million compared with the first six months of 2015. This was a consequence of the drop in performance combined with some changes to our product mix. This item therefore represents 40.7 % of the total output of operations (previous year: 42.2 %).

Staff costs barely changed overall (€ 421.5 million compared with € 418.8 million). The positive impact of a reduced headcount was offset by wage increases and by restructuring and one-off costs relating to our Efficiency Improvement Pro-

gramme. As a result, staff costs as a percentage of the reduced total output of operations increased by 2.3 percentage points year on year to 38.9 %.

At € 166.8 million, other expenses were € 18.7 million lower than in the previous year and decreased by 0.8 percentage points as a percentage of total output of operations. This reduction can be primarily attributed to lower costs for repairs, maintenance and third-party services, as well as to lower administration costs.

#### HALF-YEAR EARNINGS

In the first six months, the KSB Group's consolidated earnings before interest and taxes (EBIT) totalled € 30.6 million (previous year: € 33.6 million). This represents a decrease of 8.9 %. The main contributory factors were the restructuring and one-off costs triggered by the Efficiency Improvement Programme. The Pumps segment contributed EBIT of € 19.4 million (previous year: € 12.8 million), the Valves segment € 0.8 million (previous year: € 4.0 million) and the Service segment € 9.9 million (previous year: € 9.7 million).

Earnings before tax (EBT), at € 24.7 million (-13.6 %), fell even more markedly compared with the prior-year figure of € 28.6 million. In addition, this value was impacted by a € 0.4 million decrease in the financial income/expense, mainly as a consequence of a poorer interest balance caused primarily by declining interest income as a result of falling interest rates on the capital market. Accordingly, the return on sales, taking into account the reduced sales revenue levels, fell to 2.3 % (previous year: 2.6 %). For some Group companies with negative contributions to earnings (in some cases due to restructuring costs), we were unable to recognise any deferred tax assets, as was also the case in the previous year. Consequently, the income tax rate remained high, at 39.6 %, compared with 37.9 % for the first half of 2015. Earnings after income taxes totalled € 14.9 million (previous year: € 17.7 million).

Earnings attributable to non-controlling interests increased from € 4.9 million to € 5.5 million, due mainly to improved contributions to earnings from our US companies. This resulted in a change in the ratio to earnings after income taxes from 27.4 % to 37.0 %.

Interim Management Report  
for the Six Months Ended 30 June 2016

Earnings attributable to shareholders of KSG AG (€ 9.4 million) were € 3.5 million lower than in the previous year (€ 12.9 million).

Earnings per ordinary share were € 5.24, compared with € 7.23 in the previous year, and € 5.50 per preference share, compared with € 7.49 in the first half of 2015.

## FINANCIAL POSITION AND NET ASSETS

### EQUITY

KSB Group equity has improved from € 870.2 million (31 December 2015) to € 872.4 million, which equates to a slight increase of 0.3%. The Group's net retained earnings for the year were the main contributory factor in this regard, with currency exchange effects practically unchanged. Dividend payments had the opposite effect. With total assets also more or less unchanged (+0.4%), the equity ratio, at 37.9%, ranged at the 2015 year-end level (38.0%).

### LIABILITIES

Compared with the 2015 year-end figure, total liabilities were also more or less unchanged (+€ 6.5 million or +0.5%). Provisions increased by € 14.7 million, due to the provisions made for our Efficiency Improvement Programme. Trade payables fell by € 13.5 million, while current income tax liabilities rose by € 4.9 million.

### INVESTMENTS

At € 34.9 million, investment in property, plant and equipment was slightly lower than the comparative prior-year figure of € 36.9 million. Our investments were concentrated in India, the USA and China, as well as in Europe. We maintained our policies for measuring depreciation and amortisation in the year under review.

### NET FINANCIAL POSITION

The KSB Group's net financial position, i.e. the difference between interest-bearing financial assets on the one hand and financial liabilities on the other, improved by € 43.0 million to € 190.6 million compared with 30 June 2015.

### LIQUIDITY

Cash flows from operating activities amounted to € 31.2 million, compared with € 22.1 million for the first six months of the previous year. Increased inventories for specific orders resulted in the tying up of resources. Lower trade payables also impacted on cash flow. The smaller volume of trade receivables and PoC (Percentage of Completion) – we recorded a tangible increase for this item in the previous year – had the opposite effect, as did the higher level of other provisions.

With our investing activities more or less unchanged, we tied up more resources in term deposits with a maturity of more than 3 months and up to 12 months (in the comparative prior-year period we freed up considerable resources). Our investing activities generated cash flows of € –49.7 million (prior-year period: € +34.4 million).

Cash flows from financing activities amounted to € –11.0 million (previous year: € –27.8 million). After having reduced financial liabilities during the previous year, we recorded practically unchanged figures for the reporting period. Lower dividend payments, down by around € 5 million, had an impact on this figure.

Cash and cash equivalents from all cash flows decreased from € 273.1 million at the beginning of the year to € 245.2 million. Exchange rate effects amounting to € +1.5 million (previous year: € +3.1 million) played a role in this decrease.

### NET ASSETS

Totals assets amounted to € 2,299.8 million as at 30 June 2016, representing an increase of € 8.7 million or 0.4% over the 2015 year end.

The changes in non-current assets (€ +16.6 million) are primarily attributable to higher deferred tax assets (€ +10.1 million). Property, plant and equipment also increased (€ +5.7 million), not least due to the addition of investments exceeding the write-downs recorded during the first half of 2016.

Inventories, at € 484.3 million, were up € 29.9 million on the 2015 year-end level. This increase was primarily due to higher inventories of work in progress for orders in hand.

At € 633.2 million, trade receivables and PoC were € 30.5 million down on the 2015 year-end level (€ 663.7 million). This was due to the lower sales revenue. The increase in other financial assets (€ + 8.2 million) can be mainly attributed to higher term deposits with a maturity of more than 3 months and up to 12 months. Such factors as higher recoverable taxes led to an increase in other non-financial assets (€ + 13.5 million).

The greater financing requirement for inventories and increased non-current assets had a negative impact on cash and cash equivalents, a development that was not entirely offset by lower trade receivables and PoC. The total figure was € 245.2 million (year-end figure in 2015: € 273.1 million).

## BOARD OF MANAGEMENT'S SUMMARY OF THE ECONOMIC SITUATION OF THE GROUP

We have not yet achieved the significant growth in orders forecast for the full year, but a crucial factor in this regard is the award of major orders in the Pumps segment. These are not due to be placed until the second half of the year, which explains why order intake in this segment has still been falling. As far as the Service segment is concerned, however, the figures achieved so far are above our expectations, while the order volume for the Valves business was lower than predicted.

Our consolidated sales revenue developed as expected over the first six months (well down on the previous year's level). As well as the currency exchange effects already referred to, a key factor has been the lower number of current project orders. In the Pumps segment, we recorded a slight increase and therefore performed better than forecast for the full year (significant decline anticipated). Sales revenue for Valves fell over the first six months, as expected. With regard to Service activities,

we will have to improve over the second half of the year in order to raise our volume, after still experiencing a slight decline in the reporting period.

The KSB Group's earnings before interest and taxes (EBIT), excluding the effects from measuring construction contracts in accordance with IAS 11, fell by € 3.0 million year on year. Similarly, earnings before tax (EBT) were € 3.9 million down on the comparative prior-year figure. This has confirmed our expectations for the performance indicators referred to above across all segments during the first half of 2016. This also applies to the return on sales. The KSB Group's net financial position improved compared with 30 June 2015, rising by € 43.0 million and exceeding our budgeted figures.

Over the first six months of this financial year, our business thus performed satisfactorily overall, measured against expectations.

## EMPLOYEES

As at 30 June 2016, 362 fewer people were employed in the KSB Group than on the same date in 2015. The total headcount of the consolidated Group companies was 15,977. The three major Regions Europe, Asia and Americas/Oceania recorded a fall in staffing numbers, while the size of the workforce in the Region Middle East/Africa remained stable. The number of employees working in the German companies fell by 136.

## REPORT ON EXPECTED DEVELOPMENTS

In the 2015 consolidated financial statements we presented a detailed estimate of how we expect the market and our sales opportunities to develop in the current year.

For the current business period we continue to anticipate a significant improvement in order intake, driven primarily by major power plant projects in China and India. We also ex-



pect the Pumps and Service segments to continue to make positive contributions. Order intake in our Valves business is likely to fall significantly (original forecast: figures maintained at prior-year levels).

From today's perspective, sales revenue will be significantly down on the previous year. We expect to see the decline referred to in our 2015 Annual Report in relation to Pumps and Valves, combined with a slight improvement in the Service segment.

We will continue to implement the Efficiency Improvement Programme mentioned above in order to achieve a long-term improvement in our profit situation. This will also include continuing with our programme to redistribute tasks within our global manufacturing network. We are creating the framework within which we can increasingly run our power plant engineering business in Asia, using mostly locally manufactured products. In addition, we are continuing to reduce the number of KSB companies and to streamline our product range. Consequently, our performance indicators for 2016 as a whole will, as announced, be significantly impacted by restructuring and one-off costs. The precise amount of these costs and, in particular, their impact on earnings for the reporting year remain difficult to forecast as a final decision is still outstanding with regard to some measures.

The operating result, in other words earnings before interest and taxes (EBIT) excluding the effects from measuring construction contracts in accordance with IAS 11, will be significantly down on the previous year depending on the level of restructuring and one-off costs. This applies to both the Pumps and Valves segments, while we are expecting to see but a moderate decline in the Service segment. Consequently, earnings before taxes (EBT) will be well down on the 2015 figure. This also means that our return on sales will be correspondingly lower.

With regard to the net financial position at the year end, we continue to anticipate only a slight decrease compared with

the € 211 million achieved in 2015. This is based on the expectation that most of the adverse impact on liquidity of the restructuring and one-off costs to be borne in 2016 will not be felt until 2017 onwards.

## FORWARD-LOOKING STATEMENTS

This report contains forward-looking statements and information that are based upon the assumptions of Management. They express our current forecasts and expectations with regard to future events. As a result, these forward-looking statements and information are exposed to risks and uncertainties that lie outside the Management's sphere of influence. We wish to point out that actual events or results may differ materially from the forward-looking statements and information mentioned, if one or more of the following opportunities or risks, or other opportunities, risks and uncertainties should materialise, or if the assumptions underlying the statements prove to be inaccurate.

## OPPORTUNITIES AND RISKS REPORT

In the 2015 Annual Report, we presented in detail the opportunities and risks we see facing our business. These have since undergone no significant reassessment.

## AUDIT REVIEW

This interim management report – as well as the underlying condensed interim consolidated financial statements – have neither been audited nor reviewed in accordance with section 317 of the German Commercial Code [HGB].

## PUBLICATION

The half-year financial report is published in the *Bundesanzeiger* [German Federal Gazette], as well as on our web site ([www.ksb.com](http://www.ksb.com)). A print version is also available on request.



## BALANCE SHEET

### ASSETS

(€ thousands)	Notes	30 June 2016	31 Dec. 2015
<b>Non-current assets</b>			
Intangible assets	1	104,255	102,075
Property, plant and equipment	1	499,490	493,831
Non-current financial assets	1	7,536	7,961
Investments accounted for using the equity method	1	28,326	29,235
Deferred tax assets		94,434	84,360
		<b>734,041</b>	<b>717,462</b>
<b>Current assets</b>			
Inventories	2	484,278	454,411
Trade receivables and PoC	3	633,173	663,740
Other financial assets	3	164,361	156,169
Other non-financial assets	3	38,741	25,200
Cash and cash equivalents	4	245,165	273,136
Assets held for sale		–	934
		<b>1,565,718</b>	<b>1,573,590</b>
		<b>2,299,759</b>	<b>2,291,052</b>

### EQUITY AND LIABILITIES

(€ thousands)	Notes	30 June 2016	31 Dec. 2015
<b>Equity</b>	5		
Subscribed capital		44,772	44,772
Capital reserve		66,663	66,663
Revenue reserves		612,004	609,159
Equity attributable to shareholders of KSB AG		723,439	720,594
Non-controlling interests		148,992	149,623
		<b>872,431</b>	<b>870,217</b>
<b>Non-current liabilities</b>			
Deferred tax liabilities		14,063	13,039
Provisions for employee benefits	6	548,989	541,256
Other provisions	6	1,370	1,379
Financial liabilities	7	142,168	133,504
		<b>706,590</b>	<b>689,178</b>
<b>Current liabilities</b>			
Provisions for employee benefits	6	68,155	73,613
Other provisions	6	111,853	99,450
Financial liabilities	7	38,264	44,316
Trade payables	7	225,359	238,848
Other financial liabilities	7	89,330	85,911
Other non-financial liabilities	7	172,840	179,139
Income tax liabilities	7	14,937	10,082
Liabilities held for sale		–	298
		<b>720,738</b>	<b>731,657</b>
		<b>2,299,759</b>	<b>2,291,052</b>

# STATEMENT OF COMPREHENSIVE INCOME

## INCOME STATEMENT

(€ thousands)	Notes	Six months ended 30 June 2016	Six months ended 30 June 2015*
<b>Sales revenue</b>	8	1,064,581	1,098,670
Changes in inventories		16,195	43,619
Work performed and capitalised		2,511	2,226
<b>Total output of operations</b>		<b>1,083,287</b>	<b>1,144,515</b>
Other income	9	10,905	11,356
Cost of materials	10	-440,676	-482,570
Staff costs	11	-421,539	-418,779
Depreciation and amortisation expense		-29,972	-30,504
Other expenses	12	-166,808	-185,488
Other taxes		-6,626	-6,479
		<b>28,571</b>	<b>32,051</b>
Financial income	13	3,528	4,337
Financial expense	13	-9,332	-9,400
Income from / expense to investments accounted for using the equity method	13	1,915	1,589
		<b>-3,889</b>	<b>-3,474</b>
<b>Earnings before income taxes</b>		<b>24,682</b>	<b>28,577</b>
Taxes on income	14	-9,770	-10,831
<b>Earnings after income taxes</b>		<b>14,912</b>	<b>17,746</b>
Attributable to:			
Non-controlling interests	15	5,517	4,858*
<b>Shareholders of KSB AG</b>		<b>9,395</b>	<b>12,888*</b>
Diluted and basic earnings per ordinary share (€)	16	5.24	7.23*
Diluted and basic earnings per preference share (€)	16	5.50	7.49*

## STATEMENT OF INCOME AND EXPENSE RECOGNISED IN EQUITY

(€ thousands)	Six months ended 30 June 2016	Six months ended 30 June 2015*
<b>Earnings after income taxes</b>	<b>14,912</b>	<b>17,746</b>
Remeasurement of defined benefit plans	41	-5,000
Taxes on income	-	1,500
<b>Expense and income recognised directly in equity and not reclassified to profit or loss in subsequent periods</b>	<b>41</b>	<b>-3,500</b>
Currency translation differences	-1,059	25,338
Attributable to: Expense and income recognised directly in equity attributable to investments accounted for using the equity method	-916	2,093
Changes in the fair value of financial instruments	1,446	1,719
Taxes on income	-475	-134
<b>Expense and income recognised directly in equity and reclassified to profit or loss in subsequent periods</b>	<b>-88</b>	<b>26,923</b>
<b>Other comprehensive income</b>	<b>-47</b>	<b>23,423</b>
<b>Total comprehensive income</b>	<b>14,865</b>	<b>41,169</b>
Attributable to:		
Non-controlling interests	1,824	14,483*
<b>Shareholders of KSB AG</b>	<b>13,041</b>	<b>26,686*</b>

\* Adjustment under IAS 8

Also see the relevant information in the Notes.

## STATEMENT OF CHANGES IN EQUITY

(€ thousands)	Subscribed capital of KSB AG	Capital reserve of KSB AG
<b>1 Jan. 2015 (published)</b>	44,772	66,663
Prior-year correction with retrospective adjustment of equity	–	–
<b>1 Jan. 2015 (adjusted)</b>	44,772	66,663
Other comprehensive income	–	–
Earnings after income taxes	–	–
<b>Total comprehensive income</b>	–	–
Dividends paid	–	–
Capital increases / decreases	–	–
Change in consolidated Group / Step acquisitions	–	–
Other	–	–
<b>30 June 2015 (adjusted)</b>	<b>44,772</b>	<b>66,663</b>

(€ thousands)	Subscribed capital of KSB AG	Capital reserve of KSB AG
<b>1 Jan. 2016</b>	44,772	66,663
Other comprehensive income	–	–
Earnings after income taxes	–	–
<b>Total comprehensive income</b>	–	–
Dividends paid	–	–
Capital increases / decreases	–	–
Change in consolidated Group / Step acquisitions	–	–
Other	–	–
<b>30 June 2016</b>	<b>44,772</b>	<b>66,663</b>

Accumulated currency translation differences (€ thousands)	Equity attributable to shareholders of KSB AG	Non-controlling interests	Total equity
Balance at 1 Jan. 2015 (adjusted)	–53,146	–18,006	–71,152
Change in 2015	15,799	9,539	25,338
<b>Balance at 30 June 2015 (adjusted)</b>	<b>–37,347</b>	<b>–8,467</b>	<b>–45,814</b>
Balance at 1 Jan. 2016	–61,498	–8,496	–69,994
Change in 2016	2,699	–3,758	–1,059
<b>Balance at 30 June 2016</b>	<b>–58,799</b>	<b>–12,254</b>	<b>–71,053</b>

## Statement of Changes in Equity

## Revenue reserves

Revenue reserves							
Other comprehensive income							
Other revenue reserves	Currency translation differences	Changes in the fair value of financial instruments	Remeasurement of defined benefit plans	Equity attributable to shareholders of KSB AG	Non-controlling interests	Total equity	
788,712	-52,986	-3,993	-146,679	696,489	132,719	829,208	
-856	-160	-	-5,520	-6,536	-2,968	-9,504	
787,856	-53,146	-3,993	-152,199	689,953	129,751	819,704	
-	15,799	1,499	-3,500	13,798	9,625	23,423	
12,888	-	-	-	12,888	4,858	17,746	
12,888	15,799	1,499	-3,500	26,686	14,483	41,169	
-15,111	-	-	-	-15,111	-2,118	-17,229	
-	-	-	-	-	-	-	
-165	-	-	-	-165	-	-165	
-264	-	-	-	-264	-	-264	
785,204	-37,347	-2,494	-155,699	701,099	142,116	843,215	

## Revenue reserves

Revenue reserves							
Other comprehensive income							
Other revenue reserves	Currency translation differences	Changes in the fair value of financial instruments	Remeasurement of defined benefit plans	Equity attributable to shareholders of KSB AG	Non-controlling interests	Total equity	
813,771	-61,498	-3,342	-139,772	720,594	149,623	870,217	
-	2,699	906	41	3,646	-3,693	-47	
9,395	-	-	-	9,395	5,517	14,912	
9,395	2,699	906	41	13,041	1,824	14,865	
-9,857	-	-	-	-9,857	-2,455	-12,312	
-	-	-	-	-	-	-	
-	-	-	-	-	-	-	
-339	-	-	-	-339	-	-339	
812,970	-58,799	-2,436	-139,731	723,439	148,992	872,431	

## STATEMENT OF CASH FLOWS

(€ thousands)	Six months ended 30 June 2016	Six months ended 30 June 2015*
<b>Cash flow</b>	<b>71,487</b>	<b>55,747</b>
Other changes in cash flows from operating activities	–40,294	–33,659
<b>Cash flows from operating activities</b>	<b>31,193</b>	<b>22,088</b>
<b>Cash flows from investing activities</b>	<b>–49,681</b>	<b>34,400*</b>
<b>Cash flows from financing activities</b>	<b>–10,977</b>	<b>–27,776*</b>
Changes in cash and cash equivalents	–29,465	28,712*
Effects of exchange rate changes on cash and cash equivalents	1,494	3,124
Effects of changes in consolidated Group	–	–97
Cash and cash equivalents at beginning of period	273,136	278,552*
<b>Cash and cash equivalents at end of period</b>	<b>245,165</b>	<b>310,291*</b>

\* Adjustment under IAS 8

## NOTES

### GENERAL INFORMATION ON THE GROUP AND THE ACCOUNTING PRINCIPLES APPLIED

The accompanying unaudited condensed interim consolidated financial statements of KSB Aktiengesellschaft, Frankenthal/Pfalz, Germany (KSB AG) have been prepared in accordance with the International Financial Reporting Standards (IFRSs) issued by the International Accounting Standards Board (IASB) and as adopted by the European Union (EU), taking account of the interpretations of the IFRS Interpretations Committee (IFRIC). They have been prepared in euros (€) on a going concern basis. Amounts in this report are generally presented in thousands of euros (€ thousands) using standard commercial rounding rules and in condensed form pursuant to IAS 34.

We applied the standards and interpretations applicable as at 1 January 2016 in the preparation of the interim consolidated financial statements. Those standards and interpretations that were required to be applied for the first time had no impact on the Group's net assets, financial position or results of operations.

The adjustments and reclassifications under IAS 8 carried out at the 2015 year end were applied to the statement of comprehensive income, the statement of changes in equity and the statement of cash flows, as well as to the related disclosures in the notes. For further information, please refer to our 2015 Annual Report, Section I. General Information on the Group – Adjustments under IAS 8.

### BASIS OF CONSOLIDATION

In addition to KSB AG, 9 German and 81 foreign companies were fully consolidated in the interim consolidated financial statements. We used the equity method to consolidate five joint ventures and one associate company.

NINOMIT VPH-Tekniikka Oy, a company previously not consolidated due to there being no material impact, was merged with the fully consolidated company KSB Finland Oy on 1 January 2016. The resulting impact on these interim consolidated financial statements was not material.

The new company PT. KSB Sales Indonesia, established in 2016, was included in the group of consolidated companies on a fully consolidated basis. The already fully consolidated PT. KSB Sales Indonesia holds 99 % of the shares in this company, with KSB Aktiengesellschaft holding the remaining 1 %. The resulting impact on these interim consolidated financial statements was not material.

There were no changes to consolidation methods or currency translation methods.

## ACCOUNTING POLICIES

The accounting policies have not changed as against the last financial statements and apply to all companies included in the interim consolidated financial statements.

## BALANCE SHEET DISCLOSURES

### 1 Fixed assets

In the first six months of 2016 we invested € 34,889 thousand in property, plant and equipment; in the first half of 2015 the corresponding figure was € 36,929 thousand. At € 28,056 thousand, depreciation and amortisation hardly changed compared with the previous year (€ 28,618 thousand).

As in the first half of 2015, we did not recognise any impairment losses on intangible assets and items of property, plant and equipment in the reporting period.

The value of investments accounted for using the equity method fell from € 29,235 thousand to € 28,326 thousand, due to such factors as negative currency effects.

### 2 Inventories

(€ thousands)	30 June 2016	31 Dec. 2015
Raw materials, consumables and supplies	165,651	163,123
Work in progress	179,981	163,716
Finished goods and goods purchased and held for resale	120,019	115,027
Advance payments	18,627	12,545
	<b>484,278</b>	<b>454,411</b>



### 3 Trade receivables and PoC as well as other financial and non-financial assets

(€ thousands)	30 June 2016	31 Dec. 2015
<b>Trade receivables and PoC</b>	<b>633,173</b>	<b>663,740</b>
Trade receivables	488,088	524,610
Trade receivables from other investments, associates and joint ventures	35,954	36,193
thereof from other investments	10,092	8,316
thereof from associates	–	330
thereof from joint ventures	25,862	27,547
Receivables recognised by PoC	109,131	102,937
Receivables recognised by PoC (excl. advances received from customers PoC)	185,501	185,605
Advances received from customers (PoC)	–76,370	–82,668
<b>Other financial assets</b>	<b>164,361</b>	<b>156,169</b>
Receivables from loans to other investments, associates and joint ventures	3,699	3,189
Currency forwards	1,886	1,978
Other receivables and other current assets	158,776	151,002
<b>Other non-financial assets</b>	<b>38,741</b>	<b>25,200</b>
Other tax assets	24,512	18,210
Deferred income	14,229	6,990

Impairment losses on trade receivables amount to € 35,774 thousand (previous year: € 35,560 thousand) and on receivables from other investments to € 3,366 thousand (previous year: € 3,644 thousand). Like in the previous year, no impairment losses were recognised on receivables from joint ventures and from associates.

### 4 Cash and cash equivalents

Cash and cash equivalents are term deposits with short maturities and call deposits, and also current account balances.

### 5 Equity

There was no change in the share capital of KSB AG as against the previous year. In accordance with the Articles of Association, it totals € 44,771,963.82 and, as in the previous year, is composed of 886,615 ordinary shares and 864,712 preference shares. Each no-par-value share represents an equal notional amount of the share capital. All shares are no-par-value bearer shares.

Non-controlling interests relate primarily to PAB GmbH, Frankenthal, and the interests it holds, as well as to our companies in India and China. KSB AG holds a 51 % interest in PAB GmbH, while Klein Pumpen GmbH, Frankenthal, holds a 49 % interest.

Details of the changes in equity accounts and non-controlling interests are presented in the Statement of Changes in Equity.

## 6 Provisions

(€ thousands)	30 June 2016	31 Dec. 2015
Employee benefits	617,144	614,869
Pensions and similar obligations	533,145	526,033
Other employee benefits	83,999	88,836
Other provisions	113,223	100,829
Warranty obligations and contractual penalties	52,186	52,234
Provisions for restructuring	22,440	3,372
Miscellaneous other provisions	38,597	45,223
	<b>730,367</b>	<b>715,698</b>

The pension obligations in the KSB Group include defined contribution and defined benefit plans and contain both obligations from current pensions and future pension benefit entitlements. Plan assets are offset to a small extent in relation to the obligation.

Most of the provisions for pensions result from defined benefit plans in place for the German Group companies. Provisions for other employee benefits relate primarily to profit-sharing, jubilee payments and partial retirement obligations.

The provisions for warranty obligations and contractual penalties reported under other provisions cover the statutory and contractual obligations to customers and are based on estimates prepared using historical data for similar products and services. Miscellaneous other provisions include, inter alia, provisions for expected losses from uncompleted transactions and onerous contracts, customer bonuses and environmental measures. Risks of litigation are covered if the recognition criteria for a provision are met.

## 7 Liabilities

### NON-CURRENT LIABILITIES

(€ thousands)	30 June 2016	31 Dec. 2015
<b>Financial liabilities</b>	<b>142,168</b>	<b>133,504</b>
Loan against borrower's note	122,394	122,371
Bank loans and overdrafts	19,065	10,069
Finance lease liabilities	608	954
Other	101	110

### CURRENT LIABILITIES

(€ thousands)	30 June 2016	31 Dec. 2015
<b>Financial liabilities</b>	<b>38,264</b>	<b>44,316</b>
Loan against borrower's note	–	–
Bank loans and overdrafts	37,153	42,739
Finance lease liabilities	345	436
Liabilities to other investments, associates and joint ventures	757	1,131
Other	9	10
<b>Trade payables</b>	<b>225,359</b>	<b>238,848</b>
Trade payables to third parties	224,074	236,879
Liabilities to other investments, associates and joint ventures	1,285	1,969
<b>Other financial liabilities</b>	<b>89,330</b>	<b>85,911</b>
Advances received from customers (PoC)	44,200	49,418
Currency forwards	5,830	6,843
Interest rate swaps	652	745
Miscellaneous other financial liabilities	38,648	28,905
<b>Other non-financial liabilities</b>	<b>172,840</b>	<b>179,139</b>
Advances received from customers	90,991	87,173
Social security and liabilities to employees	46,985	54,080
Tax liabilities (excluding income taxes)	18,414	19,884
Prepaid expenses	11,338	12,744
Investment grants and subsidies	5,112	5,258
<b>Income tax liabilities</b>	<b>14,937</b>	<b>10,082</b>

## INCOME STATEMENT DISCLOSURES

### 8 Sales revenue

The KSB Group's consolidated sales revenue was € 1,064,581 thousand (previous year: € 1,098,670 thousand).

The impact of the percentage of completion method pursuant to IAS 11 and the breakdown of sales revenue by segment (Pumps, Valves and Service) is presented in the segment reporting.

### 9 Other income

(€ thousands)	Six months ended 30 June 2016	Six months ended 30 June 2015
Income from disposal of assets	846	648
Reversal of impairment losses on receivables	1,370	1,223
Currency translation gains	1,103	206
Income from the reversal of provisions	1,359	3,100
Miscellaneous other income	6,227	6,179
	<b>10,905</b>	<b>11,356</b>

### 10 Cost of materials

(€ thousands)	Six months ended 30 June 2016	Six months ended 30 June 2015
Cost of raw materials, production supplies and of goods purchased and held for resale	401,720	443,156
Cost of purchased services	38,956	39,414
	<b>440,676</b>	<b>482,570</b>

### 11 Staff costs

(€ thousands)	Six months ended 30 June 2016	Six months ended 30 June 2015
Wages and salaries	341,992	335,524
Social security contributions and employee assistance costs	65,270	65,761
Pension costs	14,277	17,494
	<b>421,539</b>	<b>418,779</b>

Pension costs are reduced by the interest component of provisions for pensions and similar obligations, which is reported as an interest cost in financial income/expense.

We employed an average of 16,094 people in the reporting period (previous year: 16,371).

## Notes

**12 Other expenses**

(€ thousands)	Six months ended 30 June 2016	Six months ended 30 June 2015
Losses from asset disposals	145	137
Losses from current assets (primarily impairment losses on receivables)	2,915	2,666
Currency translation losses	–	432
Other staff costs	11,507	13,009
Repairs, maintenance, third-party services	39,467	45,193
Selling expenses	39,458	40,668
Administrative expenses	39,145	46,479
Rents and leases	13,517	14,211
Miscellaneous other expenses	20,654	22,693
	<b>166,808</b>	<b>185,488</b>

Miscellaneous other expenses relate to such expenses as warranties, contractual penalties and additions to provisions.

**13 Financial income / expense**

(€ thousands)	Six months ended 30 June 2016	Six months ended 30 June 2015
<b>Financial income</b>	<b>3,528</b>	<b>4,337</b>
Income from equity investments	139	–
thereof from other investments	(139)	(–)
Interest and similar income	3,369	4,328
thereof from other investments	(42)	(35)
thereof from investments accounted for using the equity method	(9)	(19)
Other financial income	20	9
<b>Financial expense</b>	<b>–9,332</b>	<b>–9,400</b>
Interest and similar expenses	–9,316	–9,376
thereof to other investments	(–)	(–)
Write-downs on other investments	–	–
Write-downs on investments accounted for using the equity method	–	–
Expenses from the remeasurement of financial instruments	–	–
Other financial expense	–16	–24
<b>Income from / expense to investments accounted for using the equity method</b>	<b>1,915</b>	<b>1,589</b>
<b>Financial income / expense</b>	<b>–3,889</b>	<b>–3,474</b>

Interest and similar expenses include the interest cost on pension provisions amounting to € 5,871 thousand (previous year: € 5,652 thousand).

**14 Taxes on income**

All income-related taxes of the consolidated companies and deferred taxes are reported in this item. Other taxes are reported in the income statement after other expenses.

(€ thousands)	Six months ended 30 June 2016	Six months ended 30 June 2015
Effective taxes	19,151	18,184
Deferred taxes	-9,381	-7,353
	<b>9,770</b>	<b>10,831</b>

**15 Earnings after income taxes – Non-controlling interests**

The net profit attributable to non-controlling interests amounts to € 6,201 thousand (previous year: € 5,685 thousand) and the net loss attributable to non-controlling interests amounts to € 684 thousand (previous year: € 827 thousand). They relate primarily to PAB GmbH, Frankenthal, Germany, and the interests it holds, as well as to our companies in India.

**16 Earnings per share**

(€)	Six months ended 30 June 2016	Six months ended 30 June 2015
Diluted and basic earnings per ordinary share	5.24	7.23*
Diluted and basic earnings per preference share	5.50	7.49*

\* Adjustment under IAS 8 in the amount of € 0.03

An additional dividend attributable to preference shareholders of € 0.26 (previous year: € 0.26) per share is assumed.

**FINANCIAL RISKS**

We are exposed to certain financial risks as a consequence of our business activities. These risks can be classified into three areas:

On the one hand, we are exposed to credit risk. We define credit risk as potential default or delays in the receipt of contractually agreed payments. We are also exposed to liquidity risk, which is the risk that an entity will be unable to meet its financial obligations, or will be unable to meet them in full. In addition, we are exposed to market price risk. The risk of exchange rate or interest rate changes may adversely affect the economic position of the Group. Risks from fluctuations in the prices of financial instruments are not material for us.

We limit all of these risks through an appropriate risk management system, and define how these risks are addressed through guidelines and work instructions. In addition, we monitor the current risk characteristics continuously and regularly provide the information obtained in this way to the Board of Management and the Supervisory Board in the form of standardised reports and individual analyses.

## SEGMENT REPORTING

Segment reporting is prepared in accordance with IFRS 8 based on the management approach and corresponds to our internal organisational and management structure as well as the reporting lines to the Board of Management as the chief operating decision maker. In our matrix organisation, management decisions are primarily taken on the basis of the key performance indicators – order intake, external sales revenue and earnings before interest and taxes (EBIT) – determined for the Pumps, Valves and Service segments, excluding the effects from measuring construction contracts under IAS 11. Reporting the relevant assets, number of employees and inter-segment sales revenue for these segments is not part of our internal reporting. The managers in charge of the segments, which are geared to product groups, have profit and loss responsibility. They identify business opportunities across markets and industries and assess our options based on current and future market requirements. They also proactively encourage the development of new products and improvements to the available range of products. In this context, they work closely with our Sales organisation and Operations.

The **Pumps** segment includes single- and multistage pumps, submersible pumps and associated control and drive systems. Applications include process engineering, building services, water and waste water transport, energy conversion and solids transport.

The **Valves** segment covers butterfly, globe, gate, control, diaphragm and ball valves, as well as associated actuators and control systems. Applications primarily include process engineering, building services, energy conversion and water transport.

The **Service** segment covers the installation, commissioning, start-up, inspection, servicing, maintenance and repair of pumps, related systems and valves for all applications; as well as modular service concepts and system analyses for complete systems.

Our companies can be allocated to one or more segments based on their business activities.

The amounts disclosed for the individual segments have been established in compliance with the accounting policies of the underlying interim consolidated financial statements.

Transfer prices for intercompany sales are determined on an arm's length basis.

There were no discontinued operations in the period under review, as in the comparative period of the previous year.

The **order intake** by segment presents order intake generated with third parties and non-consolidated Group companies.

The **external sales revenue** by segment presents sales revenue generated with third parties and non-consolidated Group companies. The effects from measuring construction contracts in accordance with IAS 11 are presented separately as reconciliation effects.



The following table shows earnings before interest and taxes (EBIT) and consolidated earnings before taxes (EBT) including non-controlling interests. The effects from measuring construction contracts in accordance with IAS 11 are presented separately as reconciliation effects.

(€ thousands / Six months ended 30 June)	Order intake		External sales revenue		EBIT	
	2016	2015	2016	2015	2016	2015
Pumps segment	690,831	745,851	714,234	704,587	19,404	12,830
Valves segment	180,241	198,062	172,586	184,782	782	4,036
Service segment	227,181	208,871	181,979	185,348	9,947	9,697
Reconciliation	–	–	–4,218	23,953	496	7,062
<b>Total</b>	<b>1,098,253</b>	<b>1,152,784</b>	<b>1,064,581</b>	<b>1,098,670</b>	<b>30,629</b>	<b>33,625</b>
				Financial income – Interest and similar income	3,369	4,328
				Financial expense – Interest and similar expenses	–9,316	–9,376
				<b>Earnings before income taxes (EBT)</b>	<b>24,682</b>	<b>28,577</b>

The EBIT of the Pumps segment includes depreciation and amortisation expense of € 20.6 million (previous year: € 20.3 million), the EBIT of the Valves segment includes depreciation and amortisation expense of € 4.6 million (previous year: € 5.1 million) and the EBIT of the Service segment includes depreciation and amortisation expense of € 4.8 million (previous year: € 5.1 million).

€ 287,713 thousand (previous year: € 288,057 thousand) of the sales revenue presented was generated by the companies based in Germany, € 116,662 thousand (previous year: € 129,683 thousand) was generated by the companies based in France, € 107,672 thousand (previous year: € 96,519 thousand) by the companies based in the USA, and € 552,534 thousand (previous year: € 584,411 thousand) by the other Group companies.

There were no relationships with individual customers that accounted for a material proportion of Group sales revenue.

At the reporting date, the total non-current assets of the KSB Group amounted to € 520,819 thousand (year-end figure in 2015: € 513,057 thousand), with € 179,362 thousand (year-end figure in 2015: € 177,596 thousand) being attributable to the companies based in Germany and € 341,457 thousand (year-end figure in 2015: € 335,461 thousand) being attributable to the other Group companies. They include intangible assets, property, plant and equipment and investments accounted for using the equity method; non-current financial instruments and deferred tax assets are not included.

## OTHER DISCLOSURES

### Contingent liabilities (contingencies and commitments)

Contingent liabilities and other financial obligations and commitments fall within the scope of what is required to carry on normal business activities. They have not changed materially compared with those at 31 December 2015.

### Related party disclosures

Pursuant to section 21(1) of the *WpHG* [*Wertpapierhandelsgesetz* – German Securities Trade Act], KSB Stiftung [KSB Foundation], Stuttgart, notified us on 21 May 2008 that its voting interest in KSB AG, Frankenthal/Pfalz exceeded the 75.00 % threshold on 5 May 2008 and amounted to 80.24 % (711,453 voting shares) on this date. 0.54 % of the voting rights (4,782 voting shares) were held directly by KSB Stiftung, Stuttgart, and 79.70 % (706,671 voting shares) were attributed to KSB Stiftung, Stuttgart, pursuant to section 22(1), sentence 1, No. 1 of the *WpHG*. The voting rights attributed to KSB Stiftung, Stuttgart, were held by Klein Pumpen GmbH, Frankenthal.

The transactions in relation to the parent company Klein Pumpen GmbH are based on a rental and services agreement between KSB AG and Klein Pumpen GmbH.

No expenses (previous year: € 24 thousand) and no income (previous year: € 7 thousand) were recognised at KSB AG in relation to Klein Pumpen GmbH in the reporting period. As in the previous year, no receivables or liabilities were recognised as at June 2016.

### Auditors

PricewaterhouseCoopers Aktiengesellschaft Wirtschaftsprüfungsgesellschaft, based in Frankfurt am Main with an office in Mannheim, were appointed as auditors and group auditors for financial year 2016 at the Annual General Meeting of KSB AG on 11 May 2016.

This half-year financial report has been neither reviewed nor audited in accordance with section 317 of the *HGB* [German Commercial Code].

### Events after the reporting period

There were no reportable events after the reporting date.

### German Corporate Governance Code

The Board of Management and Supervisory Board of KSB AG issued the current statement of compliance with the recommendations of the Government Commission on the German Corporate Governance Code in accordance with section 161 of the *AktG* [*Aktiengesetz* – German Public Companies Act]. The statement of compliance is published on our web site ([www.ksb.com](http://www.ksb.com)) and has thus been made permanently accessible.

## APPROPRIATION OF THE 2015 NET RETAINED EARNINGS OF KSB AG

The Annual General Meeting on 11 May 2016 resolved to appropriate the 2015 net retained earnings of € 9,857,123.62 of KSB AG, Frankenthal, as follows:

Distribution of a dividend of € 5.50 per ordinary no-par-value share	4,876,382.50 €
and, in accordance with the Articles of Association, € 5.76 per preference no-par-value share	4,980,741.12 €

The dividend was paid out on 12 May 2016.

## RESPONSIBILITY STATEMENT

To the best of our knowledge, and in accordance with the applicable interim reporting principles, the interim consolidated financial statements give a true and fair view of the assets, liabilities, financial position and profit or loss of the Group, and the interim group management report includes a fair review of the development and performance of the business and the position of the Group, together with a description of the principal opportunities and risks associated with the expected development of the Group during the remainder of the financial year.

Frankenthal, 12 August 2016

The Board of Management

## CONTACTS

### EDITOR

KSB Aktiengesellschaft  
Johann-Klein-Straße 9  
67227 Frankenthal, Germany  
Tel. +49 6233 86-0  
Fax +49 6233 86-3401

### ONLINE NEWS

You will find the latest news  
on the KSB Group at [www.ksb.com](http://www.ksb.com)

Should you need additional information,  
please contact:

### INVESTOR RELATIONS

Ralf Pfundmaier  
Tel. +49 6233 86-2053  
Fax +49 6233 86-3454  
E-mail: [investor-relations@ksb.com](mailto:investor-relations@ksb.com)

### COMMUNICATIONS

Ullrich Bingenheimer  
Tel. +49 6233 86-2138  
Fax +49 6233 86-3456  
E-mail: [ullrich.bingenheimer@ksb.com](mailto:ullrich.bingenheimer@ksb.com)

### CONCEPT AND DESIGN

KSB Communications  
Frankenthal, Germany

### PRINTING

Ottweiler Druckerei und Verlag GmbH  
Ottweiler, Germany

## FINANCIAL CALENDAR

### 10 NOVEMBER 2016

Interim report

January – September 2016

### 30 JANUARY 2017

Preliminary report on

financial year 2016

### 30 MARCH 2017

Financial press conference

Frankenthal, Germany

### 31 MARCH 2017

Invitation to

Annual General Meeting

### 28 APRIL 2017

Interim report

January – March 2017

### 10 MAY 2017

Annual General Meeting

Frankenthal, Germany



**KSB Aktiengesellschaft**  
Johann-Klein-Straße 9  
67227 Frankenthal (Germany)  
[www.ksb.com](http://www.ksb.com)